

Makes Transformer and Inductor Design Easy



Magnetics Designer

Create Better Designs Faster and With Confidence

Magnetics Designer provides a fast and simple way to design all types of transformers and inductors, a key part of all electronic systems and power supplies. Virtually any single phase, layer or sector wound, inductor or transformer, from 10Hz to over 5MHz, can be designed and analyzed. All variations from small (planar) to large (power pole) are supported.

Magnetics Designer produces a complete transformer or inductor structure based upon your electrical specifications. A database with thousands of cores and a wide variety of materials and wire are included to cover all of your needs. You can add your own cores, wire, and material information using our supplied Excel® spreadsheet.

Magnetics Designer uses proprietary algorithms to select the appropriate core, number of turns, and wire sizes to minimize the total power dissipation for a given temperature rise in the smallest possible core. The program predicts magnetizing and leakage inductance, interwinding capacitance, peak flux density, DC and AC winding resistance, copper loss (both AC and DC), core loss, weight, temperature rise, window fill percentage and more.

Version 4.1.0 is packed with new features. Major enhancements include the ability to handle sector winding configurations and a bobbin tab that depicts the winding structure. New field solution algorithms produce magnetic field maps that describe the core flux behavior. The field solutions give you more accurate calculation of the AC resistance.

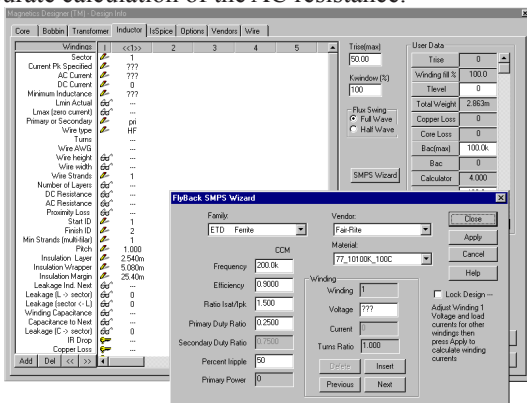

New Switch Mode Power Supply Wizards help to automate design.

intusoft

www.intusoft.com

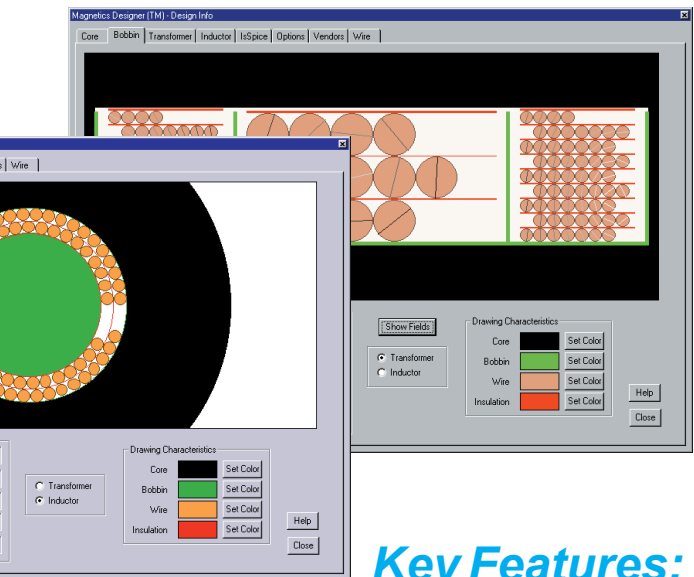

Key Features:

- Analyzes, designs, and optimizes transformers and inductors from electrical specifications -- low to high frequency (>5MHz)
- Can tackle applications like 60Hz single phase line transformers, high frequency switching regulator transformers, AC/output chokes, flyback and forward converter transformers, planar magnetics and more.
- Produces a complete winding sheet and detailed electrical performance reports.
- Contains a complete database of cores from vendors such as TDK, Magnetics, Philips, Thomson, Micrometals, Siemens, Kaschke, Vac, and Fair-Rite. You can use formvar, square or double square magnet wire, Litz wire, pcb traces, or foil including silver or aluminum compositions.
- Allows you to change over 20 design parameters such as allowed temperature rise, allowed window fill, number of turns, wire gauge and type, bobbin margins, number of parallel strands, gap length, layer insulation thickness, wrapper thickness, and end margin lengths.
- Allows you to split, move, and interleave windings and set variable size sectors.
- Offers power supply wizards which automatically compute spreadsheet entries.
- Contains power supply templates which accept IsSpice transformer models for cycle-by-cycle switching simulations.

Phone: (310) 329-3295

Fax: (310) 329-9864

Magnetics Designer

Magnetics Designer has a number of unique features that set it apart from all programs, past and present, that have attempted to tackle transformer and inductor design. The software includes a level of sophistication, ease of use, and power that no home grown approach can match.

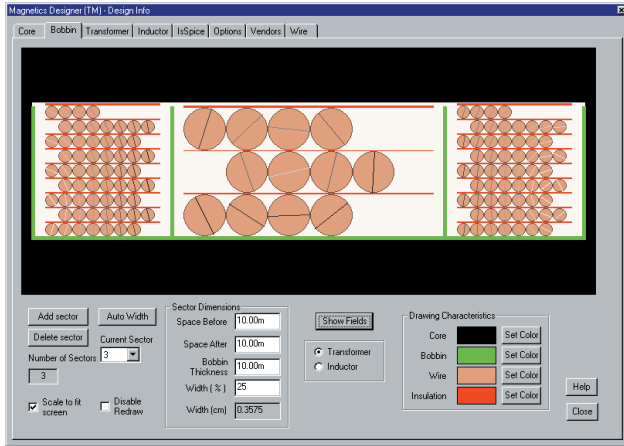

The Core Selection Screen gives you thousands of cores to choose from. You can also add your own “exotic” cores, materials, and wire information. A database of core manufacturers, core distributors, wire distributors, and transformer manufacturers is included.

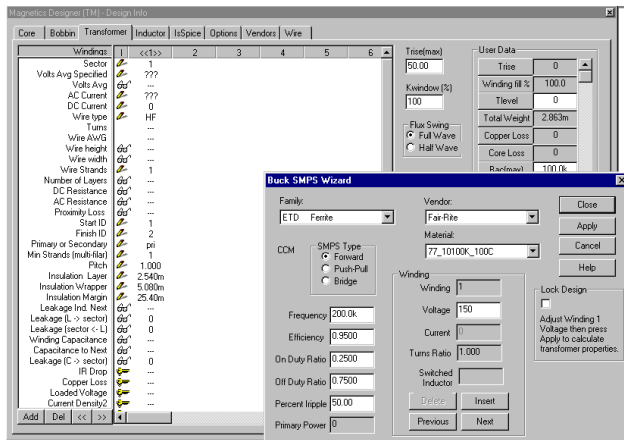

Magnetics Designer’s powerful algorithms perform thousands of optimizations allowing you to trade off over 20 different design parameters. New Switch Mode Power Supply Wizards are available for transformer coupled **Flyback** designs and **Buck Regulators** (shown above). Simply enter the power supply specification and MD computes the spreadsheet entries.

Magnetics Designer can be customized. The program exposes all of the key design variables and allows you to create your own mathematical equations with them. With this feature, you have unparalleled flexibility in deriving your own performance merits and optimization criteria.

Unique Features Set Magnetics Designer Apart

Magnetics Designer produces a Berkeley **SPICE** model of your transformer or inductor design as shown in the **SPICE Model Screen** (next). The model includes 1st and 2nd order effects such as AC/DC resistance, frequency dependent losses, leakage inductance, and interwinding capacitance. OrCAD® (Capture®), or Intusoft (SpiceNet) **schematic symbols** are also produced so that you can immediately make use of your design in a simulation.

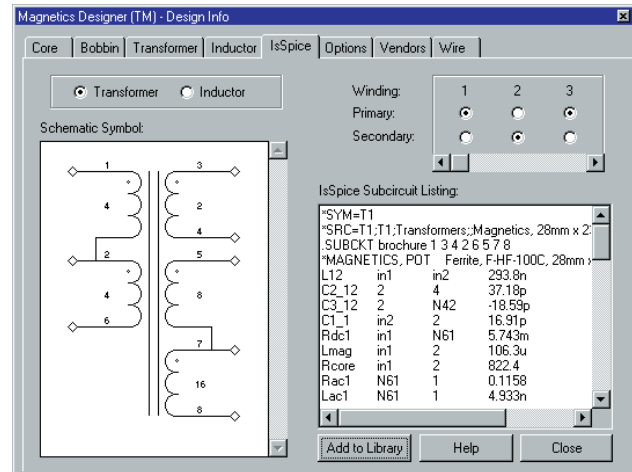

Magnetics Designer produces a detailed “winding sheet” that describes your magnetic device and how it should be constructed. You can even e-mail your design reports directly to a manufacturer.

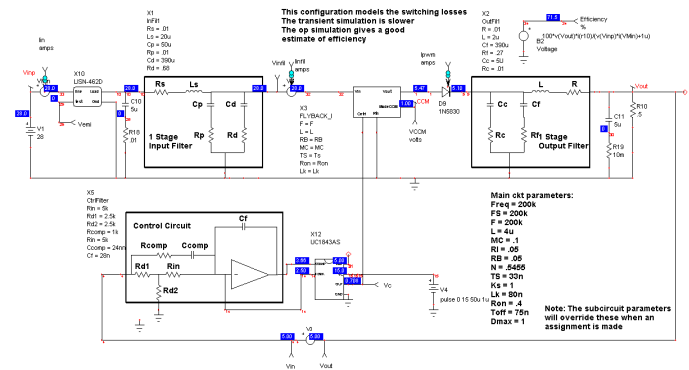

New pre-designed power supply templates, including **Flyback** (shown above), **Forward** and **Push-Pull** topologies, have been added. These templates accept the IsSpice transformer models generated using Magnetics Designer for cycle by cycle switching simulations.

Stop designing transformers and inductors using tedious hand calculations! With the features and power of **Magnetics Designer** you can create better designs faster and dramatically improve your productivity.

Download A FREE Demo Kit!
www.intusoft.com